

KENWOOD

4-CHANNEL POWER AMPLIFIER

KAC-744

INSTRUCTION MANUAL

KENWOOD CORPORATION

Take the time to read through this instruction manual.

Familiarity with installation and operation procedures will help you obtain the best performance from your new 4-channel power amplifier.

For your records

Record the serial number, found on the back of the unit in the spaces designated on the warranty card, and in the space provided below. Refer to the model and serial numbers whenever you call upon your KENWOOD dealer for information or service on the product.

Model KAC-744 Serial number _____

SYSTEM EXAMPLES

System example 1. When two KAC-744 are used as 2-channel amplifiers, a high power 4-channel amplifier can be configured.

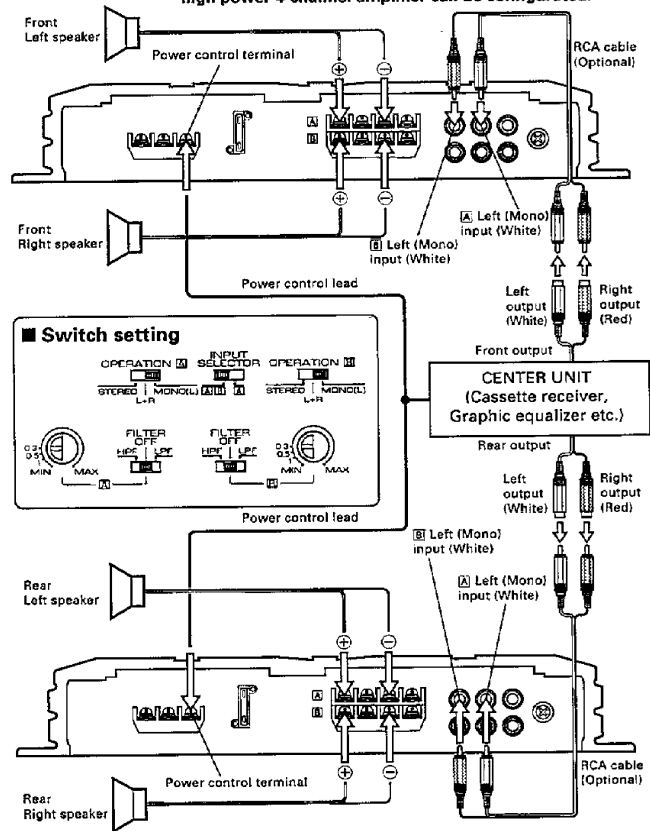

System example 2. A multi-amp system is configured with a single unit by sending the output from amplifier A through the high pass filter for use as the signal for the high frequency speaker and sending the output from amplifier B through the low pass filter for use as the signal for the low frequency speaker.

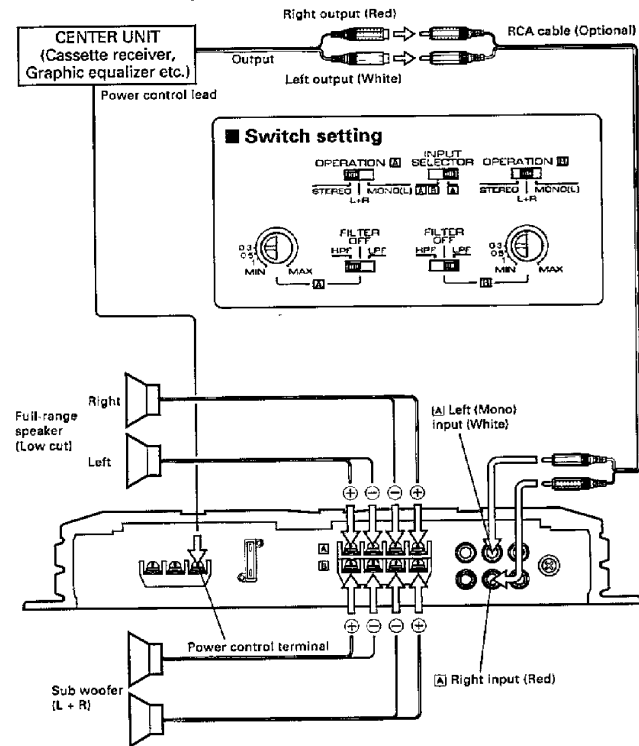

SYSTEM EXAMPLES

System example 3. Addition of subwoofer speaker using the Line output signals.

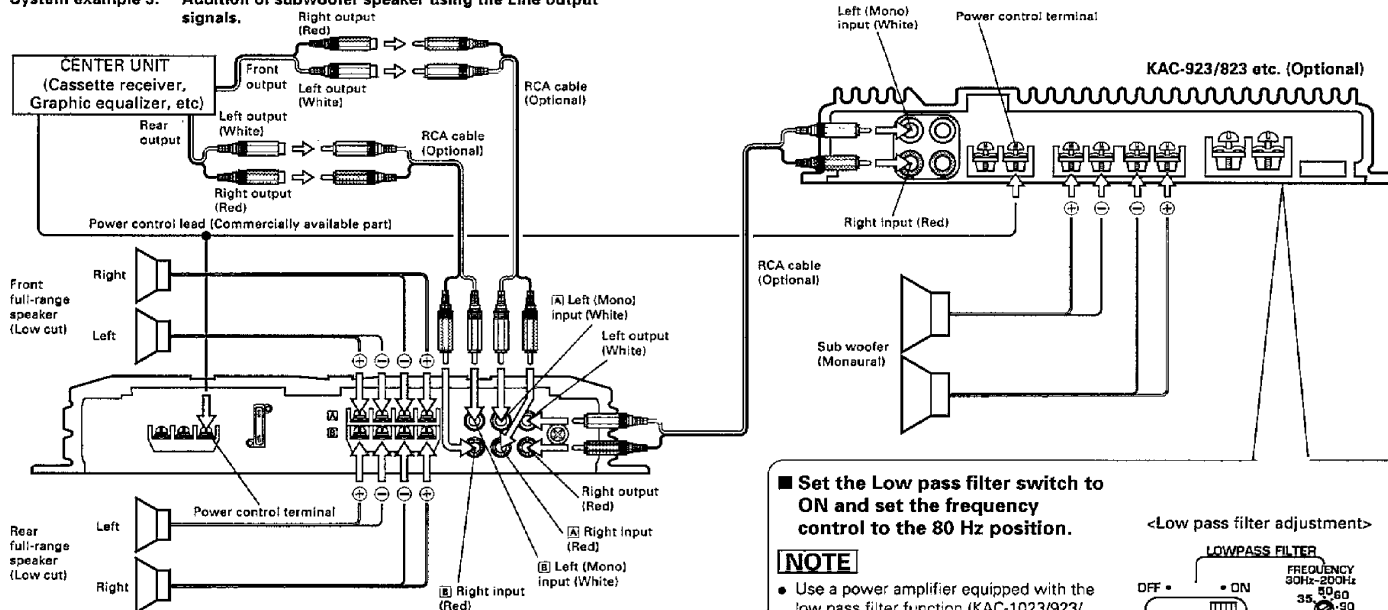

Switch setting

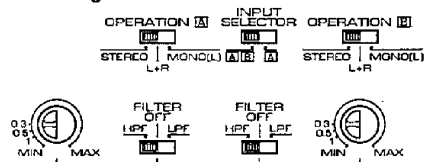

■ Set the Low pass filter switch to ON and set the frequency control to the 80 Hz position.

NOTE

- Use a power amplifier equipped with the low pass filter function (KAC-1023/923/823, etc.).
- For details on the system connection, power connection, etc., please refer to the instruction manual provided with your power amplifier.

<Low pass filter adjustment>

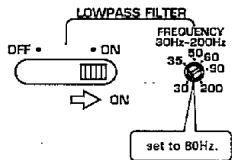

CONTROLS

■ KAC-744

This is a 4-channel amplifier including 2 stereo amplifiers in a body. One amplifier is referred to as amplifier A and the other is amplifier B.

This unit is compatible with a large variety of systems by combining the switches and functions described in the following.

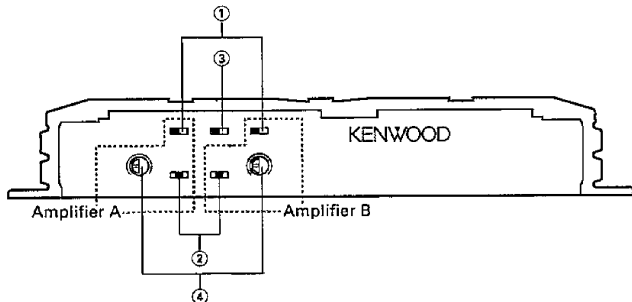

① OPERATION switch

This switch allows to select the amplification method of input signals.

● STEREO position:

The input left and right signals are amplified separately. Use this position when the unit is used as a stereo amplifier.

● L + R position:

The input left and right signals are combined before being amplified. Use this position when the unit is used for subwoofer speakers or the L + R (monaural) sound is required.

● MONO (L) position:

The input left signal is amplified twice the normal boost level. Use this position when the unit is used as a high-power monaural amplifier. (The input right signal is not output.)



② FILTER switch

This switch allows to apply a filter to the output signals.



- **HPF (High-Pass Filter) position (12dB/oct.):** Only frequencies of 80 Hz or higher are output. (Frequencies below 80 Hz are cut.)
- **LPF (Low-Pass Filter) position (12dB/oct.):** Only frequencies of 80 Hz or lower are output. (Frequencies above 80 Hz are cut.)

③ INPUT SELECTOR

This switch selects the input method of the signals to be amplified by amplifiers A and B.



- **[A] [B] position:** Amplifies both of the signals input to amplifiers A and B.
- **[A] position:** Amplifies only the signal input amplifier A with both amplifiers A and B.

④ Input sensitivity control

Adjust this control according to the pre-out level of the center unit connected to this unit.

INPUT SENSITIVITY



Center unit pre-out level	Amplifier input sensitivity
300 mV	MAX
800~1000 mV	0.3 V

NOTE

Refer to "SPECIFICATIONS" on the center unit's instruction manual about the pre-out level.

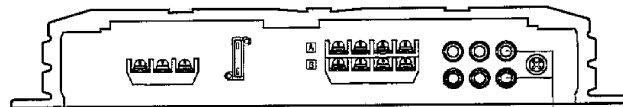

⑤ Line outputs

These jacks output respectively the signals input to amplifiers A and B. They always output the stereo signals regardless of the position of the OPERATION switch.

CONNECTIONS

■ System connection

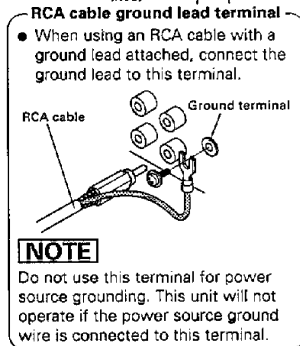
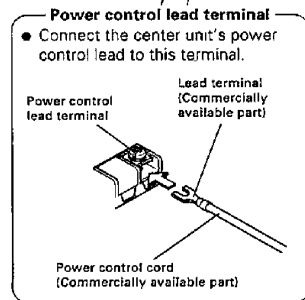
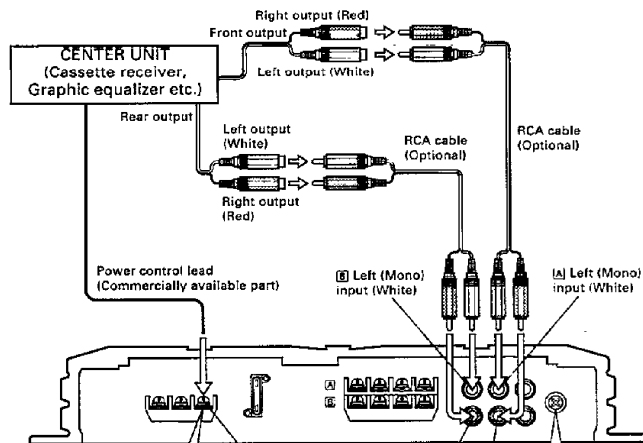

■ Power and Speakers lead connection

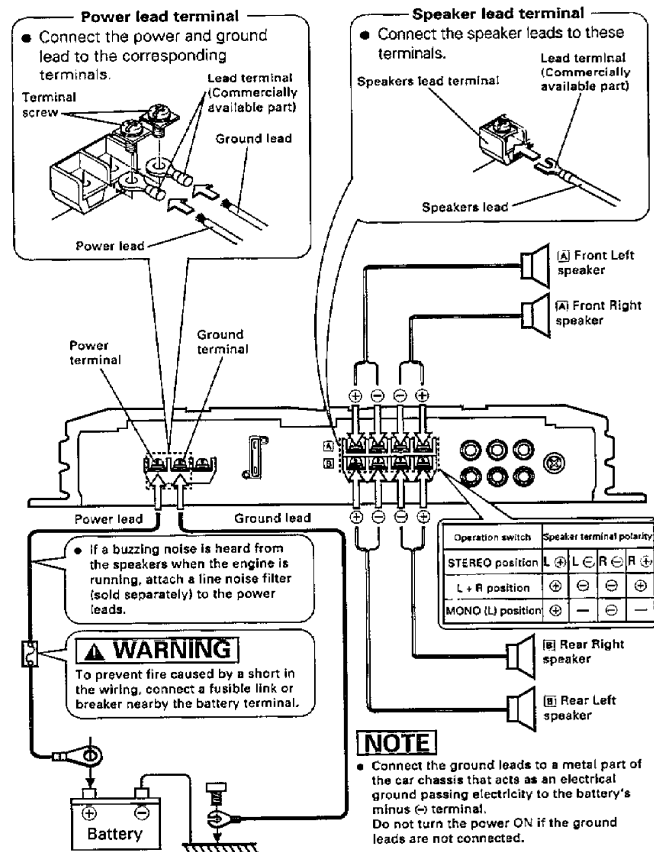

TRI-MODE

Only using coils and capacitors in the stereo 4-channel speaker system (refer below), a sub woofer can be added to the system.

- Operation switch setting



- Characteristics of coil and capacitor

- Coil (L): Passes low frequencies and blocks high frequencies. (Low pass)
- Capacitor (C): Passes high frequencies and blocks low frequencies. (High pass)

- 6dB/octave for High and Low pass filter

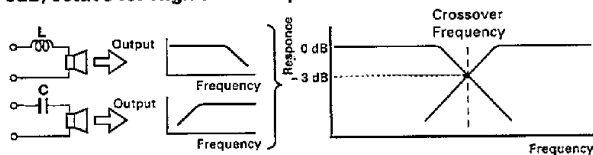

- Table of content for 6dB/octave

Cross over frequency	Speaker impedance			
	2 ohm		4 ohm	
	L (Coil)	C (Capacitor)	L (Coil)	C (Capacitor)
80 Hz	4.0 mH	1000 μ F	8.0 mH	500 μ F
100 Hz	3.2 mH	800 μ F	6.4 mH	400 μ F
150 Hz	2.1 mH	530 μ F	4.2 mH	270 μ F
200 Hz	1.6 mH	400 μ F	3.2 mH	200 μ F

- If the coils and capacitors are not available in the values listed, coils and capacitors with similar or close values can be used without affecting the performance in practical use.
- Coils and capacitors not listed in the above table can be determined using the following formulas.

$$C = \frac{159000}{f_c \times R} (\mu F) \quad L = \frac{159 \times R}{f_c} (mH)$$

f_c =Cut of Frequency (Hz) R =Speaker Impedance (Ω)

SYSTEM EXAMPLES

- When a sub woofer is added to the rear speaker system

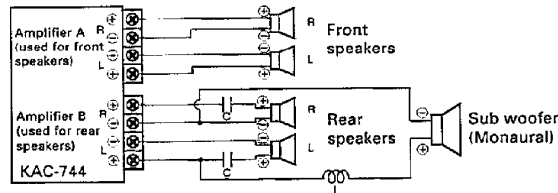

NOTE

- Using the TRI-MODE PASSIVE CROSSOVER NETWORK "KPX-T120" (optional) makes the system's wiring easier.

- When a sub woofer is added to the whole speaker system

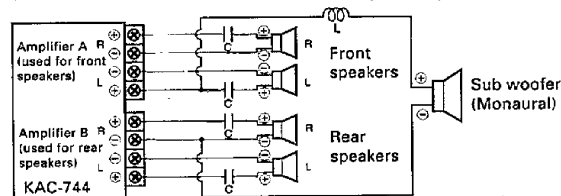

- * The sub woofer is not affected by the controls on the center unit.

CAUTION

- Be sure that the combined impedance of your speaker system as seen from the KAC-744 is at least 2 ohms. An impedance of less than 2 ohms will damage the amplifier.

INSTALLATION

■ Installation

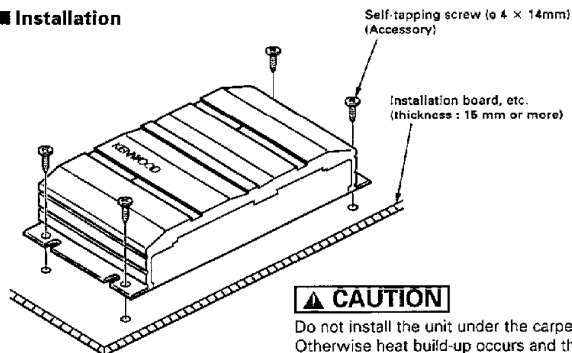

▲ CAUTION

Do not install the unit under the carpet. Otherwise heat build-up occurs and the unit may be damaged.

■ Installation location

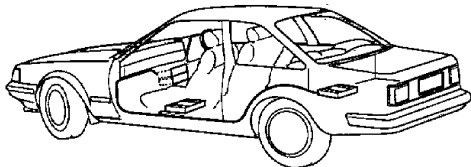

- Since the power amplifier has no parts which require operation, it can be installed at a position away from the driver's seat without any hindrances. As generally accepted positions for its installation, places such as inside the trunk, etc. can be considered.

▲ CAUTION

- Install this unit in a location which allows heat to easily dissipate. Once installed, do not place any object on top of the unit.
- After installing the unit, check to make sure that electrical equipment such as the brake lamps, turn signal lamps and windshield wipers operate normally.
- Install the unit securely in a location that does not interfere with driving.

TROUBLESHOOTING GUIDE

Often, what appears to be a malfunction is due to user error. Before calling for service, please consult the following table.

Symptom	Cause	Remedy
No sound. (No sound from one side.)	A speaker cord has become unconnected.	Check the speaker cord connections.
The level is too low (or high).	The input sensitivity adjusting knob is not set to the correct position.	Adjust correctly referring to "CONTROLS".
The sound quality is bad. (The sound is distorted.)	1. The speakers are connected to the same wires. 2. A speaker cord is pinched by a screw in the car body.	1. Connect each speaker terminal to its respective speaker output. 2. Check the speaker wiring.

SPECIFICATIONS

Specifications subject to change without notice.

Audio Section

Max Power Output (4 Ω)	
4 Channel Mode	80 W \times 4
3 Channel Mode	80 W \times 2 + 160 W
2 Channel Mode	160 W \times 2
Rated Power Output (4 Ω)	
4 Channel Mode	40 W \times 4 (20 Hz-20 kHz, less than 0.08% THD)
3 Channel Mode	40 W \times 2 (1 kHz, 0.08% THD) + 110 W \times 1 (1 kHz, 0.8%)
2 Channel Mode	110 W \times 2 (1 kHz, 0.8% THD)
Rated Power Output (2 Ω)	
4 Channel Mode	55 W \times 4 (1 kHz, 0.8% THD)
Frequency Response	2 Hz ~ 45 kHz (-3 dB)
Signal to Noise Ratio	100 dB
Sensitivity (MAX.)	0.15 V (rated output)
Sensitivity (MIN.)	3.0 V (rated output)
Input Impedance	10 k Ω
Damping Factor (100 Hz)	More than 100
High Pass Filter Frequency	80 Hz (12 dB/oct.)
Low Pass Filter Frequency	80 Hz (12 dB/oct.)

General

Operating Voltage	14.4 V (11 ~ 16 V allowable)
Current Consumption (1 kHz, 10% THD)	25 A
Dimensions (W \times H \times D)	280 \times 50 \times 230 mm
Weight	3.0 kg

SAFETY PRECAUTIONS

▲ WARNING

To Prevent fires and avoid personal injury in case of accidents.

- When extending the Power supply, or Ground lead, avoid short circuits by using 5 mm² (AWG5) or larger automotive grade cable.
- Check to be sure that no metal objects (tools, needles, coins) are left inside the unit.
- If you smell or see smoke, disconnect the unit immediately and consult your KENWOOD dealer. Continued use can cause a fire or permanent damage to the unit.
- Do not touch the unit during use because the surface of the unit becomes hot and may cause burns if touched.

▲ CAUTION

To keep the unit in proper working order.

- Be sure it's connected to a 12V DC power supply with a minus ground connection.
- Do not open front panel or top bottom cover.
- Do not exposed this unit to direct sunlight or high heat.
- Keep it clean and dry.
- Be sure it is fastened securely and not exposed to excess vibration.

NOTE

- If you have difficulty in installing this unit in your vehicle, please contact your KENWOOD dealer.

Cleaning

1. Always turn the power OFF before cleaning.
2. Wipe the front panel and other exterior surfaces with a soft dry cloth or a soft cloth lightly moistened with a neutral detergent.

▲ CAUTION

- DO NOT use abrasive pads or paint thinner, benzene, or other volatile solvents. These may remove the indicator characters.

FCC WARNING

This equipment generates and uses radio frequency energy. Changes or modifications other than those expressly approved in the instruction manual may cause interference with radio and television reception. Unauthorized changes may lead to the user's loss of the authority to operate this equipment.

ACCESSORY

Part name	External View	Number of Items
Self-tapping screws (φ 4 × 14 mm)		4

INSTALLATION PROCEDURE

1. Before starting installation, disconnect the ⊖ terminal of the battery. This will prevent short circuits.
2. Connect the Input and Output leads.
3. Connect the Ground lead to the metal body of the car.
4. Connect the Power lead.
5. Install the unit in the car.
6. Connect the negative ⊖ terminal of the battery.

▲ CAUTION

- A short circuit may cause a blown fuse. A short circuit is a serious problem that could also cause a fire. Check the wiring carefully and, if any wires are short-circuited, rewire immediately. If no short-circuits are found, replace the fuse with one having the same rating (see indication on unit).
- Check that no unconnected wires or connectors are in contact with the body of the car. Extraneous noise or current entering the system can cause malfunction or damage.